



RV1P

VARIABLE DISPLACEMENT VANE PUMPS

SERIES 10

OPERATING PRINCIPLE

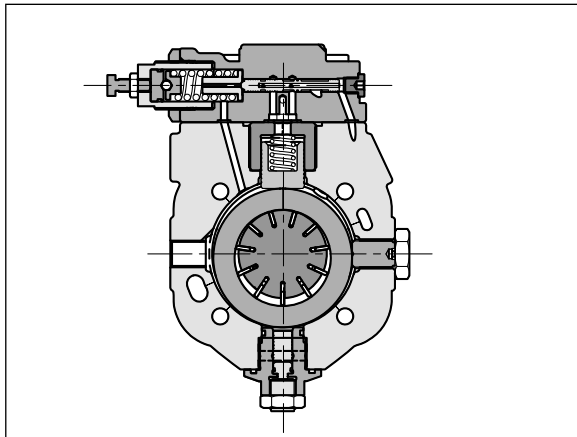

- RV1P are variable displacement vane pumps with hydraulic operated pressure compensator, that permit instantaneous adjustment of the flow rate according to the circuit requirements. Energy consumption is reduced and adequate in every cycle phase.
- The pumping group is provided with double hydrostatic axial compensation, that improves the volumetric efficiency and reduces wear of the components. Both internal paths for inlet and outlet are double.
- The pressure compensator operates keeping the cam ring of the pumping group in the eccentric position by a piston hydraulically controlled by a pressure pilot stage. When the delivery pressure equals the pressure corresponding to the pilot stage setting, the cam ring is moved toward the center, adjusting the flow rate to the plant requirements. In zero flow demand conditions, the pump delivers oil only to compensate any possible bleedings and pilotings, keeping the circuit pressure constant.
- The compensator response times are very restrained such as to allow the removal of the pressure relief valve.

TECHNICAL SPECIFICATIONS

(measured with mineral oil with viscosity of 46 cSt at 40°C)

PUMP SIZE		016	020	025	032	040	050	063	080	100	120
Geometrical displacement (UNI ISO 3662)	cm ³ /rev	16	20	25	32	40	50	63	80	100	120
Actual displacement (±3%)	cm ³ /rev	17	21	26	33	42	51	63	80	100	123
Nominal flow rate (at 1500 rpm)	l/min	25,5	31,5	39	49,5	63	76,5	94,5	120	150	184,5
Maximum operating range	bar	250									210
Pressure adjustment range	bar	20 ÷ 250							40 ÷ 250		40 ÷ 210
Maximum pressure on drain port	bar	1									
Rotation speed range	rpm	800 ÷ 1800				800 ÷ 1500					
Rotation direction		clockwise (seen from the outlet shaft side)									
Loads on the shaft		loads radial and axial not allowed									
Maximum applicable shaft torque	Nm	130	250			586			900		
Mass (RV1P-*PC)	kg	16,5	18,5			43,7			57,2		

Ambient temperature range	°C	-20 / +50
Fluid temperature range	°C	+15 / +60
Recommended viscosity	cSt	22 ÷ 68
Fluid viscosity range		see paragraph 2.2
Fluid contamination degree		see paragraph 2.3

HYDRAULIC SYMBOL

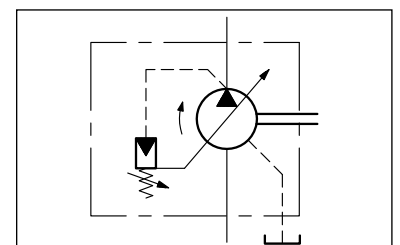



1 - IDENTIFICATION CODE

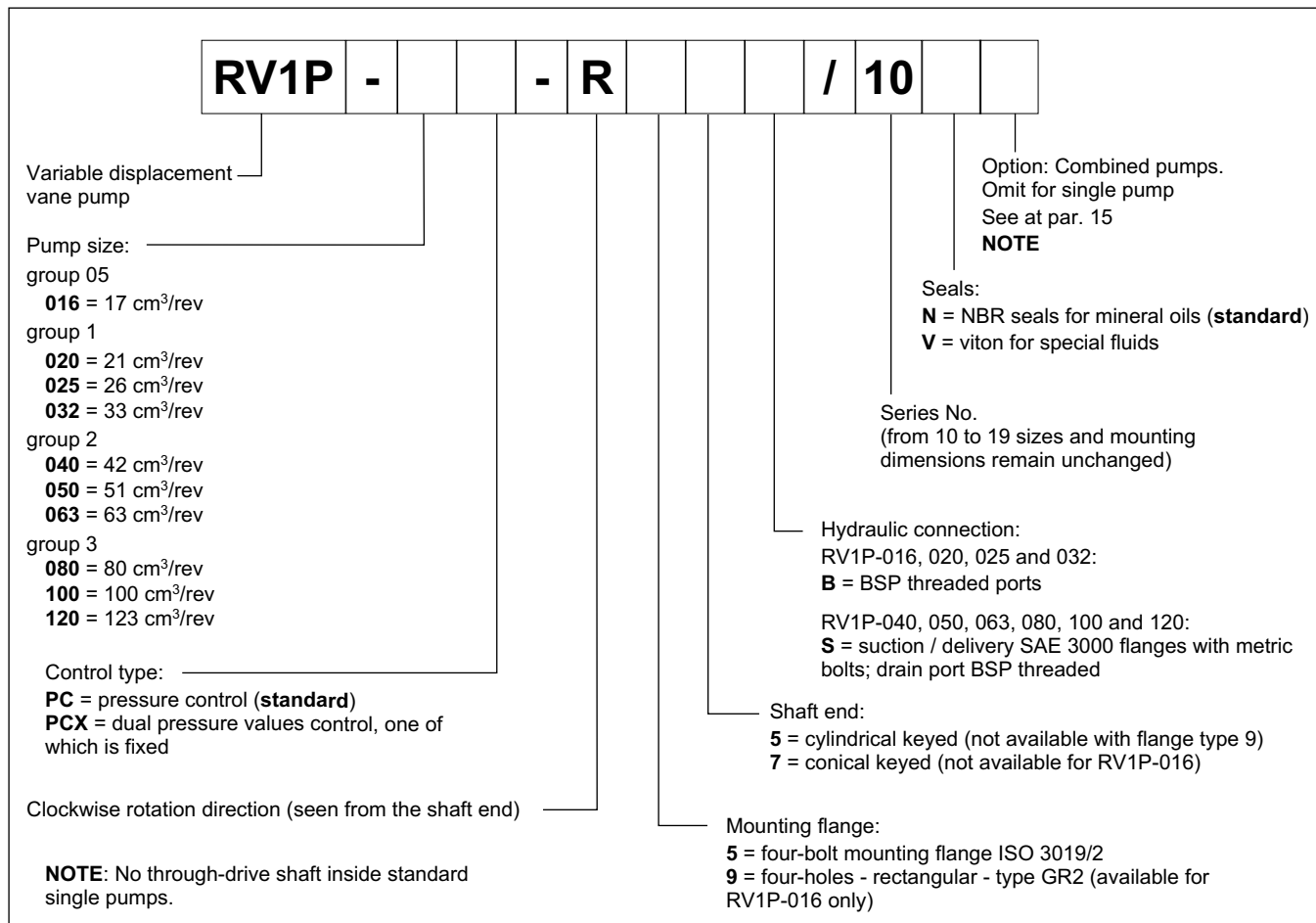

2 - HYDRAULIC FLUID

2.1 - Fluid type

Use mineral oil based hydraulic fluids with anti-foam and antioxidant additives. For use of other types of fluid, keep in mind the limitations shown in the following table or consult our technical department for approval.

FLUID TYPE	NOTES
HFC (water glycol solutions with proportion of water ≤ 40%)	<ul style="list-style-type: none"> - The values shown in the performance ratings table must be reduced by at least 50% - The pump rotation speed must be limited to 1000 rpm. - The max fluid temperature must be lower than 50°C - Use NBR seals only
HFD (phosphate esters)	<p>There are no particular limitations with this kinds of fluids. Operation with a fluid viscosity as close as possible to the optimum viscosity range specified in par. 2.2 is recommended.</p> <ul style="list-style-type: none"> - Use FPM (Viton) seals only

2.2 - Fluid viscosity

The operating fluid viscosity must be within the following range:

optimum viscosity	22 + 68 cSt	referred to the fluid working temperature in the tank
maximum viscosity	400 cSt	limited to only the start-up phase of the pump

When selecting the fluid type, be sure that the true viscosity is within the range specified above at the operating temperature.

2.3 - Degree of fluid contamination

The maximum degree of fluid contamination must be according to ISO 4406:1999 class 20/18/15; therefore, use of a filter with $\beta_{20} \geq 75$ is recommended. A degree of maximum fluid contamination according to ISO 4406:1999 class 18/16/13 is recommended for optimum endurance of the pump. Hence, use of a filter with $\beta_{10} \geq 100$ is recommended.

The suction filter must be equipped with a by-pass valve and, if possible, with a clogging indicator. See installation section for details.

3 - CHARACTERISTIC CURVES RV1P-016 (GR. 05)

(obtained with viscosity of 46 cSt at 40°C)

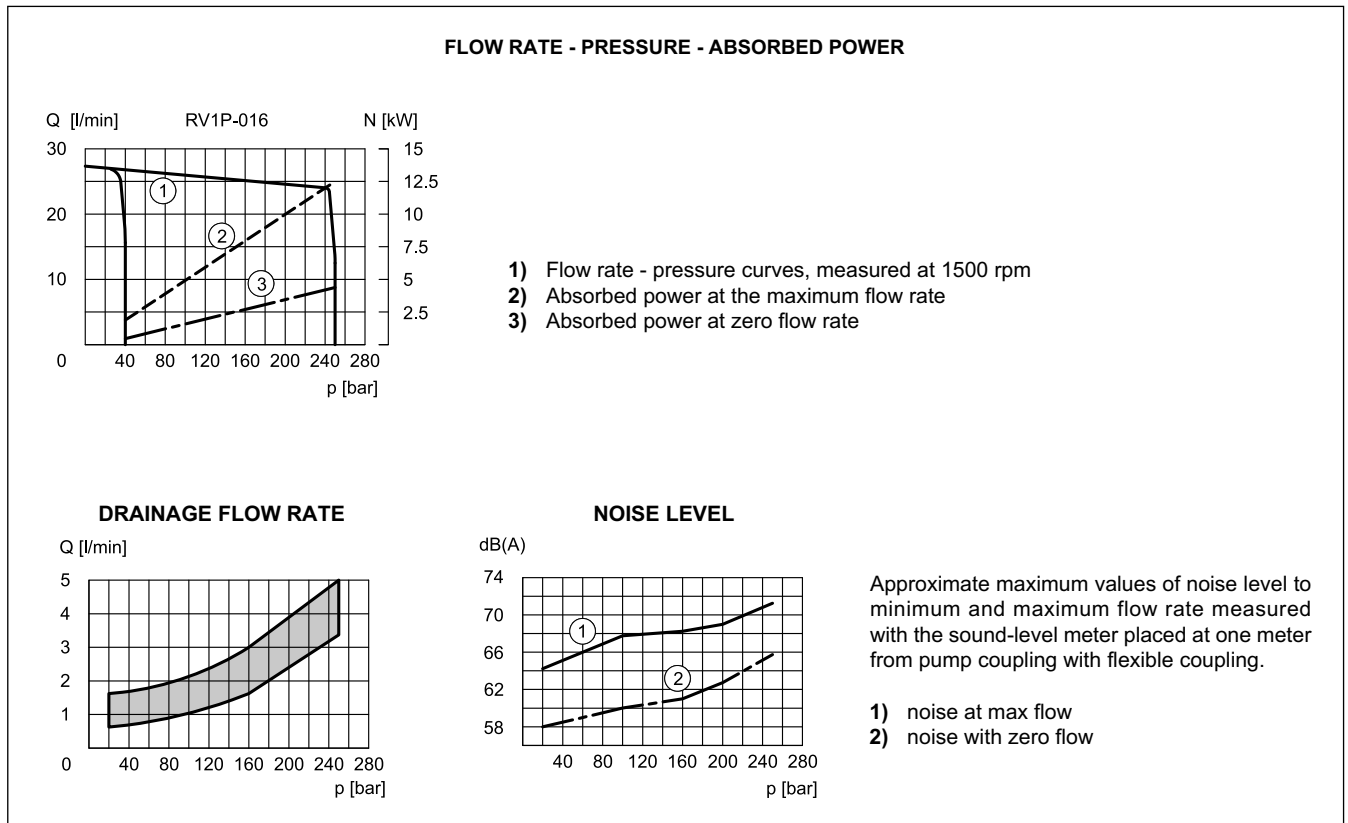

4 - CHARACTERISTIC CURVES OF RV1P-020, RV1P-025 AND RV1P-032 (GR. 1)

(obtained with viscosity of 46 cSt at 40°C)

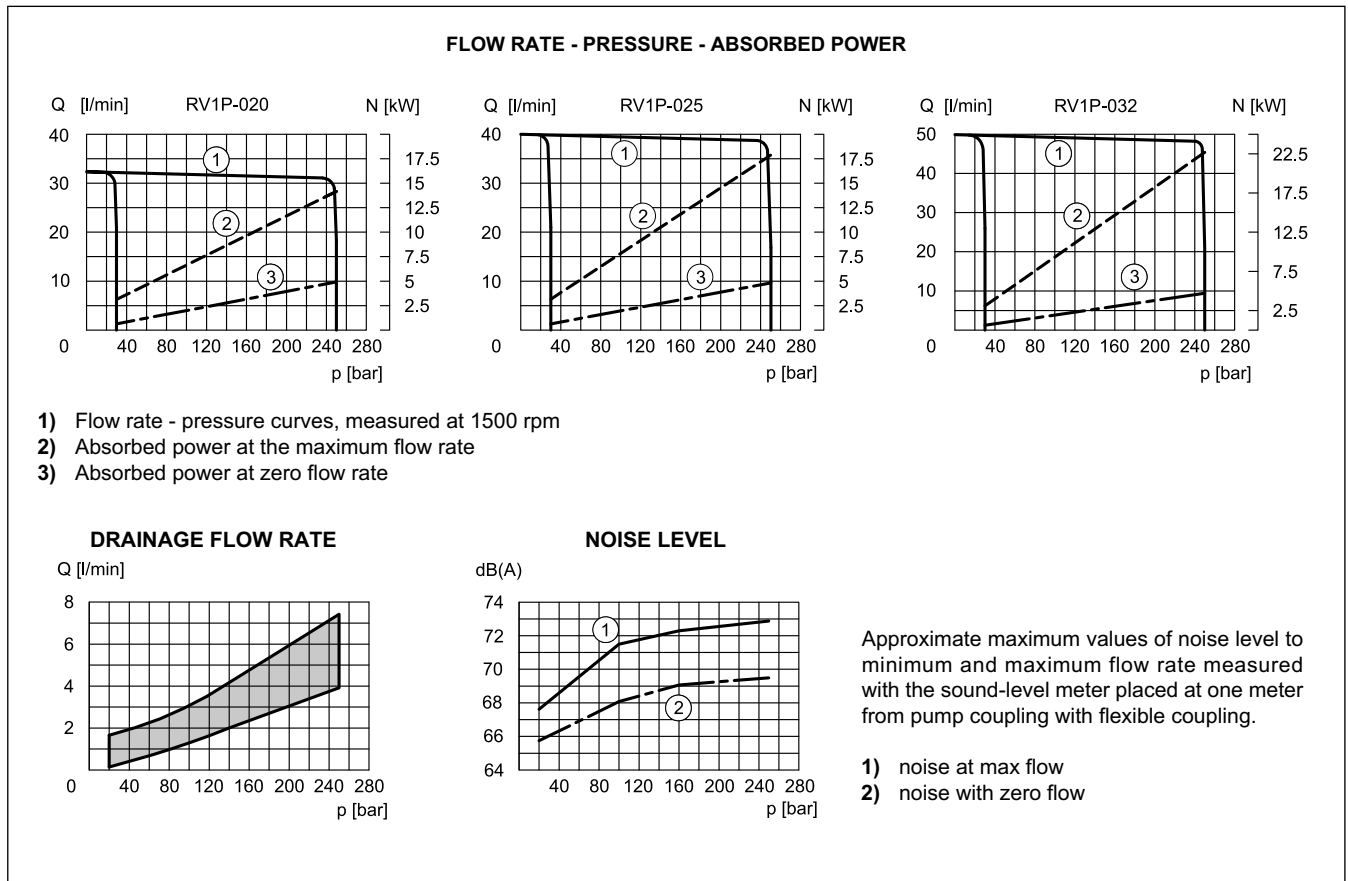

5 - CHARACTERISTIC CURVES FOR RV1P-040, RV1P-050 AND RV1P-063 (GR. 2)

(values obtained with viscosity of 46 cSt at 40°C)

FLOW RATE - PRESSURE - ABSORBED POWER

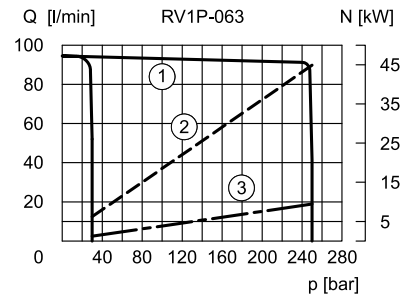
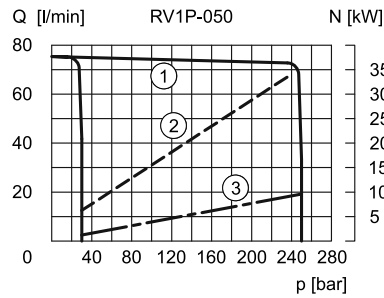
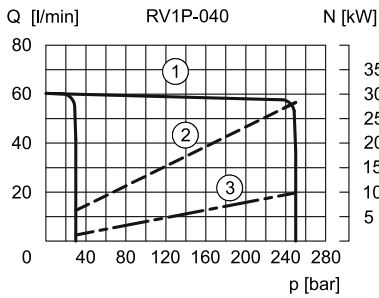

- 1) Flow rate - pressure curves, measured at 1500 rpm
- 2) Absorbed power at the maximum flow rate
- 3) Absorbed power at zero flow rate

DRAINAGE FLOW RATE

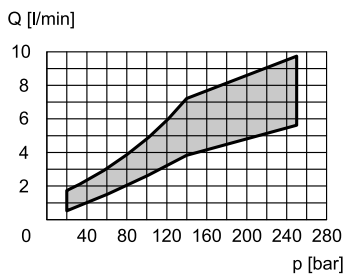

NOISE LEVEL

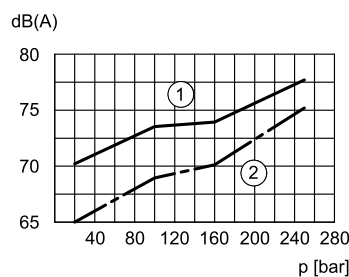

Approximate maximum values of noise level to minimum and maximum flow rate measured with the sound-level meter placed at one meter from pump coupling with flexible coupling.

- 1) noise at max flow
- 2) noise with zero flow

6 - CHARACTERISTIC CURVES FOR RV1P-080, RV1P-100, RV1P-120 (GR. 3)

(values obtained with viscosity of 46 cSt at 40°C)

FLOW RATE - PRESSURE - ABSORBED POWER

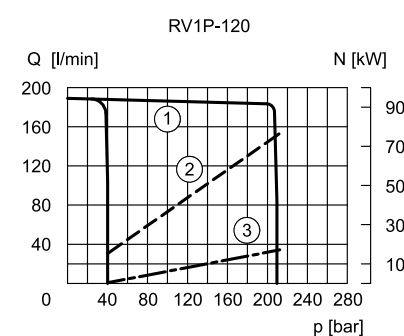
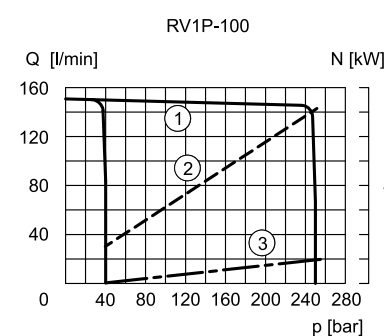
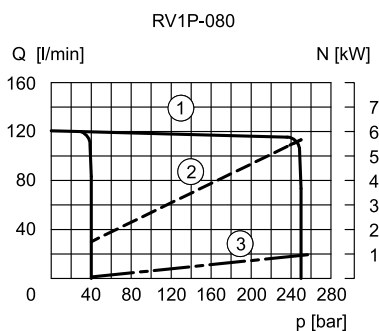

- 1) Flow rate - pressure curves, measured at 1500 rpm
- 2) Absorbed power at the maximum flow rate
- 3) Absorbed power at zero flow rate

DRAINAGE FLOW RATE

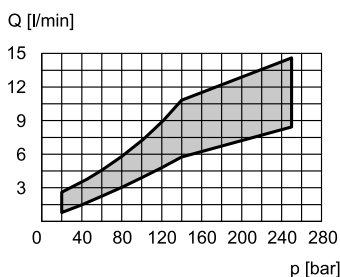

NOISE LEVEL

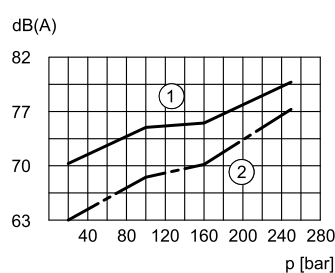

Approximate maximum values of noise level to minimum and maximum flow rate measured with the sound-level meter placed at one meter from pump coupling with flexible coupling.

- 1) noise at max flow
- 2) noise with zero flow

7 - PC PRESSURE CONTROL

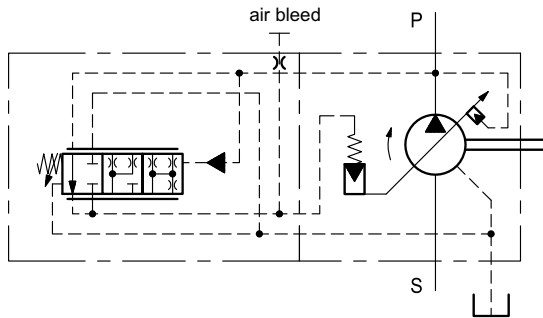

The PC pressure regulator keeps the pressure at a constant set level in the circuit, thus adjusting automatically the pump flow rate according to the real need of the system.

The desired pressure can be set by manually adjusting the screw.

Overall dimensions at sections 9, 10, 11 and 12.

FEATURES OF THE PC CONTROL:

- adjustable pressure range:

RV1P-016, 020, 025, 032, 040, 050 and 063 = 20 ÷ 250 bar

RV1P-080 and 100 = 40 ÷ 250 bar

RV1P-120 = 40 ÷ 210 bar

- default setting = 50 bar

7.1 - Response times and pressure peaks

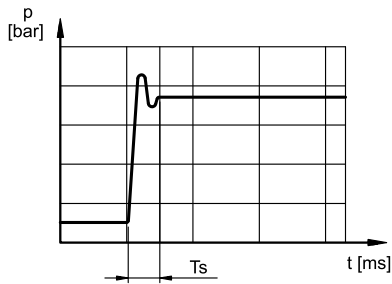

Dynamic response curves obtained by switching the solenoid operated directional valve for closing the pump outlet.

Pressure peaks exceeding 30% of the maximum operating pressure (10% for pumps gr.3) must be eliminated.

displacement	stabilization time Ts (ms)	
	15 → 210 bar	15 → 250 bar
016	50	40
020, 025, 032	80	60
040, 050, 063	100	80
080, 100, 120	120	100 (NOTE)

NOTE: for RV1P-120 range 15 → 210 bar

8 - PCX - DUAL PRESSURE CONTROL

Dual pressure value pump operating diagram

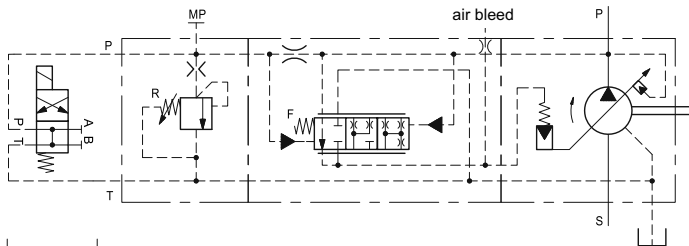

Valves that must be ordered separately:
solenoid switching valve DS3-SA2 (datasheet 41 150)

The PCX control, mated to a suitable two-position solenoid valve allows to electrically select the pump at null displacement and at a minimum delivery pressure value.

This function is useful for the start-up of a pump without load and allows to operate at minimum pressure in the system during the machine cycle pause, with considerable energy saving.

Pressure adjustment is obtained by a solenoid switching valve to be mounted on the control.

NOTE: The switching valve must be ordered separately.

FEATURES OF THE PCX CONTROL:

solenoid valve OFF = pump at null displacement and delivery pressure by fixed stage (F)

solenoid valve ON = pump at maximum displacement and delivery pressure set on control (R)

- fixed stage value (F):

- RV1P-016, 020, 025, 032, 040, 050 e 063 = 20 bar
- RV1P-080, 100 e 120 = 40 bar

- adjustable pressure range (R):

- RV1P-016, 020, 025, 032, 040, 050 and 063 = 20 ÷ 250 bar
- RV1P-080 e 100 = 40 ÷ 250 bar
- RV1P-120 = 40 ÷ 210 bar

- default setting (R) = 50 bar

8.1 - Overall dimensions RV1P-*PCX

RV1P-016

MOUNTING INTERFACE
ISO 4401-03

from RV1P-020 to RV1P-120

displacement	A (mm)
016	128
020, 025, 032	129
040, 050, 063	162,5
080, 100, 120	171,5

1	Main pressure stage. Fixed stage. Do not tamper
2	Pressure relief valve Clockwise rotation to increase pressure Socket hex screw 5/32" Locknut: hex screw 9/16"
3	Solenoid switching valve (to be ordered separately)
4	Gauge 1/4" BSP

9 - OVERALL AND MOUNTING DIMENSIONS RV1P-016 (GR. 05)

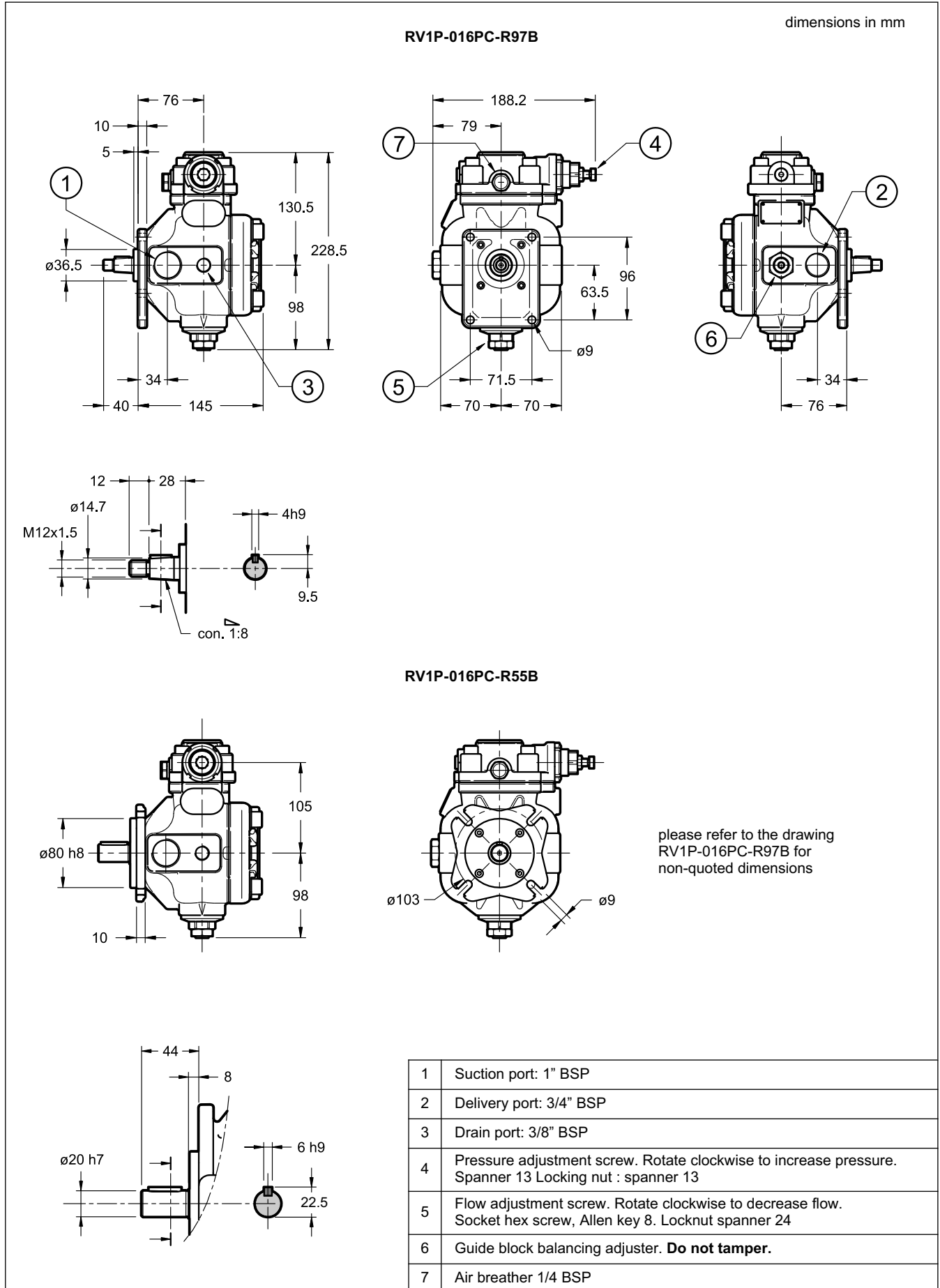

10 - OVERALL AND MOUNTING DIMENSIONS RV1P-020, RV1P-025 AND RV1P-032 (GR. 1)

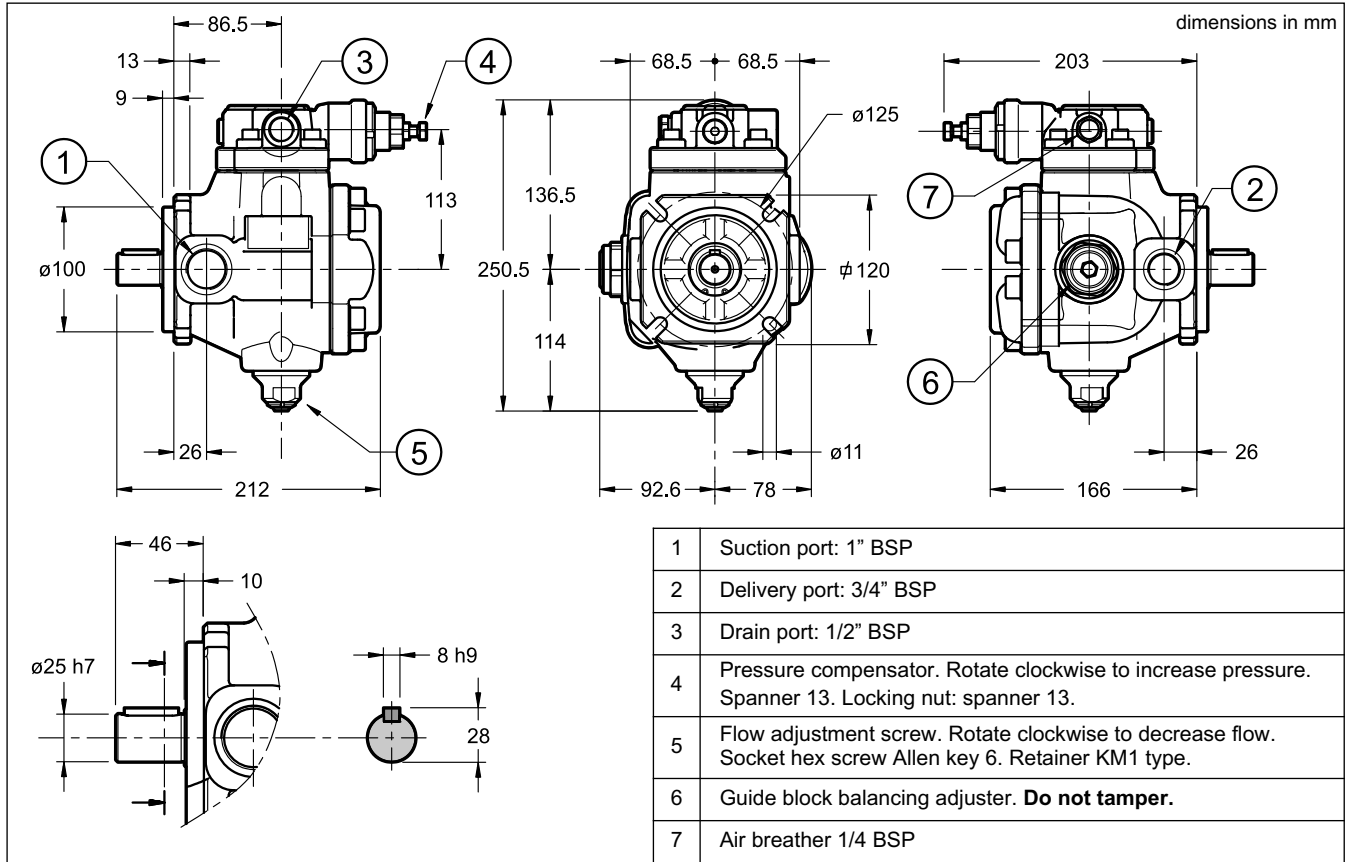

11 - OVERALL AND MOUNTING DIMENSIONS RV1P-040, RV1P-050 AND RV1P-063 (GR. 2)

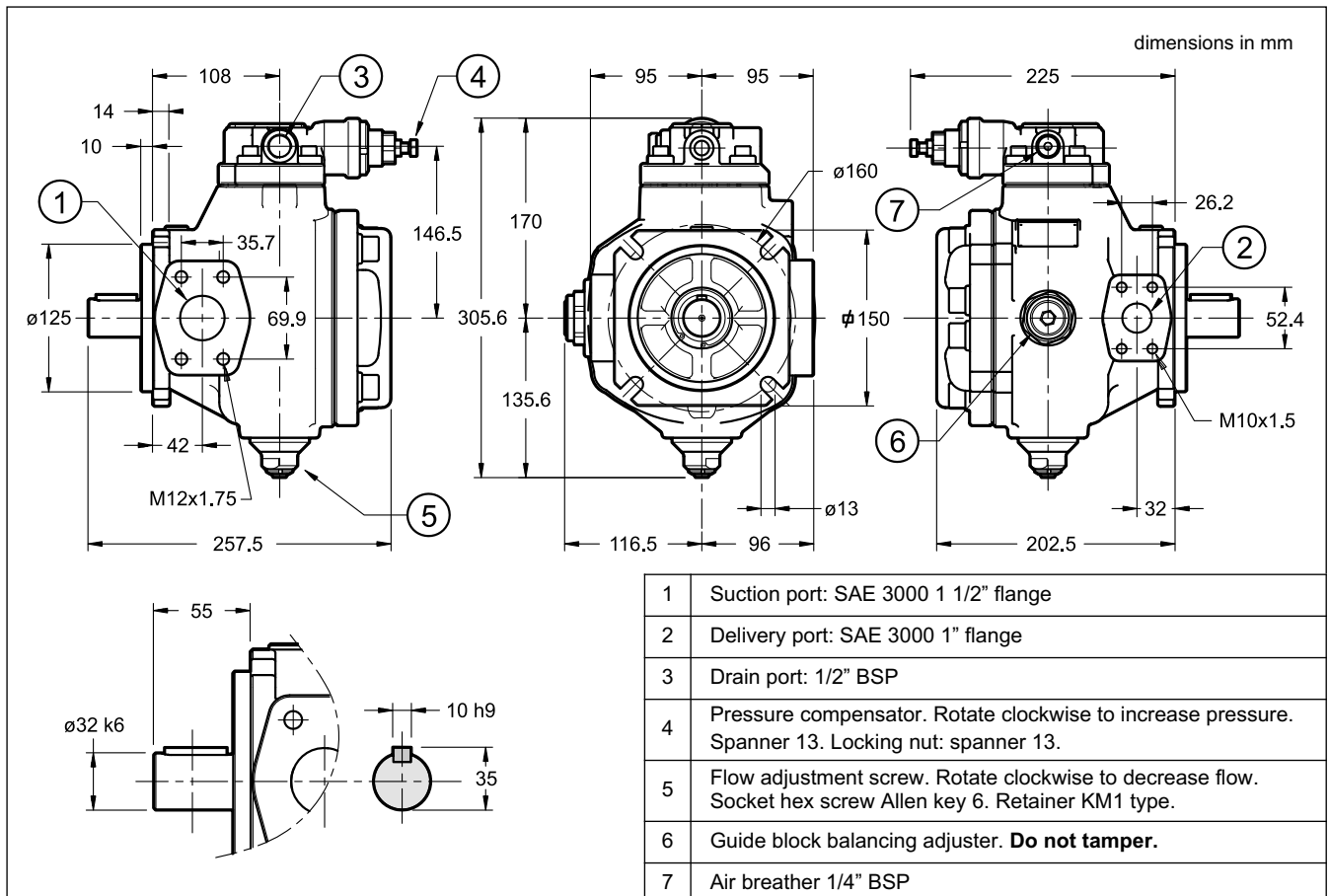

12 - OVERALL AND MOUNTING DIMENSIONS RV1P-080, RV1P-100, RV1P-120 (GR. 3)

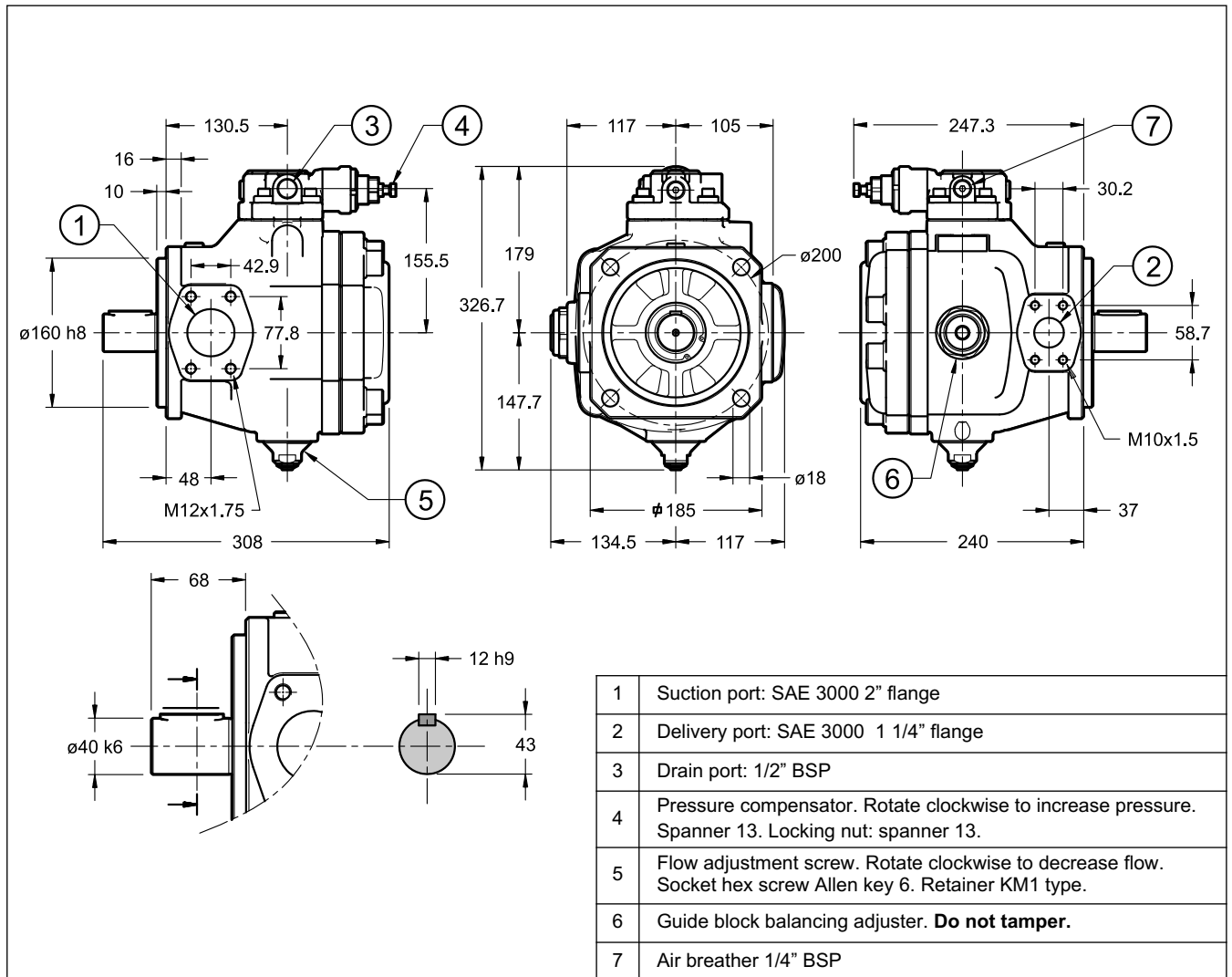



12 - INSTALLATION

The instruction manual for pumps installation and commissioning is always included in the packaging with the pump. Observe restrictions in this document and follow the instructions.

- RV1P-016, RV1P-020, RV1P-025 and RV1P-032 pumps can be installed in any position. The other pumps need to be installed with the axis in horizontal position and with pressure compensator upward.
- Motor-pump coupling must be made with a self-aligning flexible coupling with convex teeth and a polyamide cam. **Couplings that generate axial or radial loads on the pump shaft are not allowed.**
- The suction line must be short, with a small number of bends and without internal section changes. The minimum section of the inlet pipe must be equal to the section of the thread of the pump inlet port.
The pipe-end inside the tank should be cut at 45°, should have a minimum distance from the tank bottom of not less than 50 mm, and there should always be a minimum height of suction of 100 mm. **The suction pipe should be completely airtight in order to avoid air intake which could be extremely damaging to the pump.**
Suction pressure should be between 0.8 and 1.5 bar absolute.
- The drainage pipe must be connected directly to the tank by a line separate from other discharges, located as far as possible from the suction line and lengthened to below the minimum oil level in order to avoid foaming.
- The fluid tank must be suitably sized in order to exchange the thermal power generated by the various system components and to provide a low recycle rate (approximately: tank capacity = 4 times the pump flow rate per minute).
In systems where the pump runs for a long time under zero-flow setting conditions, it is advisable to provide a fluid cooling system.

The pressure in the drain line must not exceed 1 bar.

To ensure the maximum pump working life, the inlet fluid temperature must never be above 50°C. **The fluid temperature must never exceed 60 °C**

- **Ensure the pump shaft can be rotated manually without any resistance.**
- Fill the pump with the fluid through the drain port. The pump must be started-up in full displacement (P→T) with flow to the tank without pressure. During this step bleed the air, unscrewing the cap of the air bleed port on the pressure compensator device, (see drawings) and then close the cap.
The pump should prime within 5 seconds. If it does not, switch it off and investigate the cause. The pump should not run empty.
Subsequents start-up under zero flow setting conditions are admissible only with pressure not exceeding 30 bar, and with the system and pump completely filled with fluid.
- If the volume adjuster has been set for values less than 50% of the nominal flow-rate, start-up is allowed only if provided the system and pump are fully filled of fluid.
- **It's essential that the difference between the fluid temperature and the ambient temperature (pump body) doesn't exceed 20 °C.**
If this is the case, the pump should be switched-on only for intervals of about 1-2 seconds (start/stop mode) without pressure, until the temperatures came balanced.
- The pumps are usually placed directly upon the oil tank. Flooded suction port installation of the pump is recommended in the event of circuits with high flow rates and pressures.

14- VOLUME ADJUSTMENT SCREW

The volume adjuster is fitted as standard on all the pumps.

It consists of an adjustment screw and a small balanced piston that limit the maximum eccentricity of the pumping group cam ring, changing the displacement. The maximum flow is reduced by turning the adjustment screw clockwise. Indicative data, sensitive to performance tolerances.

Nominal size		016	020	025	032	040	050	063	080	100	120
Reduction of displacement per turn	cm ³	11	10			16			16		
Minimum possible displacement	cm ³ /rev	3,3	9,5	15	19	27,5	35,5	43,5	63	80	100

Tools required for adjustment:

RV1P-016: adjustment screw hexagon socket key 8. Locking nut spanner 24.
Other sizes: adjustment screw hexagon socket key 6. Tooth retainer KM1 type.

15 - MULTIPLE PUMPS

RV1P with through drive shaft are available. These pump are sdesigned to be connected one to the other in decreasing order of displacement. The RV1P-016 pump suitable for multiple pumps is the R55B version only (ISO 3019-2 four-bolt flange with cylindrical keyed shaft end)

RV1P pumps can be coupled also with RV1D type pumps (see catalogue 14 101) and with gear pumps (see catalogue 11 100). The torque on the shaft must be further reduced after the second pump.

Consult our Sales Support department for this kind of applications.

IDENTIFICATION CODE FOR MULTIPLE PUMPS

Both single pumps with through drive shaft (without mating joint) and multiple groups are available.

Fill the ordering code, by following the coupling sequence of the pumps. Insert the /F suffix after each pump with through drive shaft:

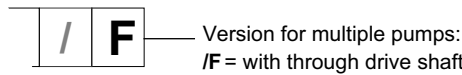

identification code front pump /F + identification code intermediate pump /F + identification code rear pump

Examples:

Single pump with through drive shaft: RV1P-025PC-R55B/10V

Double pump identification: RV1P-025PC-R55B/10V/F + RV1P-025PC-R55B/10V

Triple pump identification: RV1P-040PC-R55S/10N/F + RV1P-040PC-R55S/10N /F + RV1P-040PC-R55S/10N

RV1P pump + gear pump identification: RV1P-050PCX-R55S/10N/F + GP2-00208R97F/20N

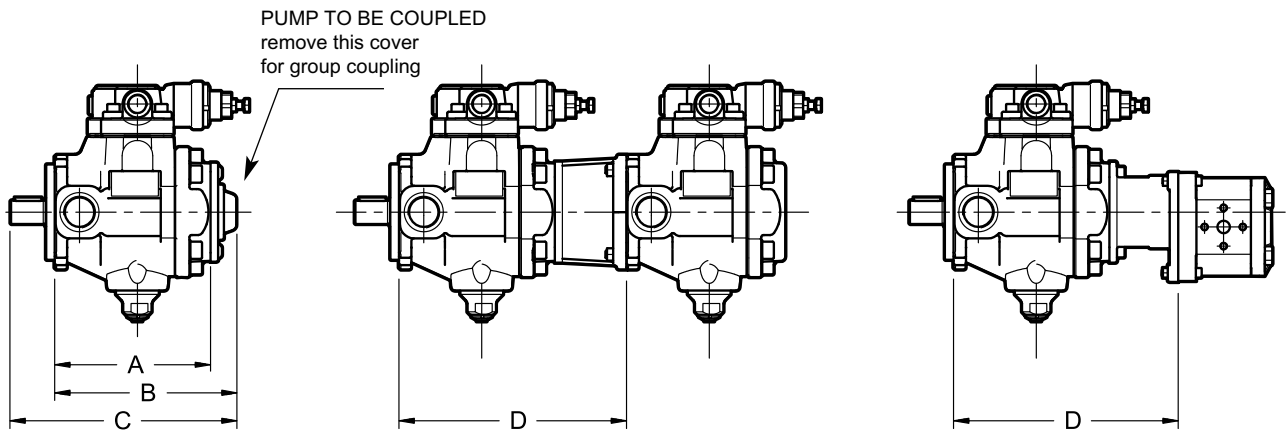

Dimensions (mm)					
Group size	A	B	C	D with RV1P pump of same size group	D with gear pump type GP1 / GP2 / GP3
05	139	166	210	212	203 / 211 / -
1	163	190	236	238	227 / 235 / -
2	199,5	246,5	301,5	301,5	289,5 / 289,5 / 290,5
3	237	284	352	354	327 / 327 / 328

Max. torque applied to the shaft of the second pump (Nm)		
Group size front pump	Second pump (same size group)	Second pump (smaller size group)
05	55	-
1	55	55
2	110	110
3	180	110

16 - CONNECTION FLANGES

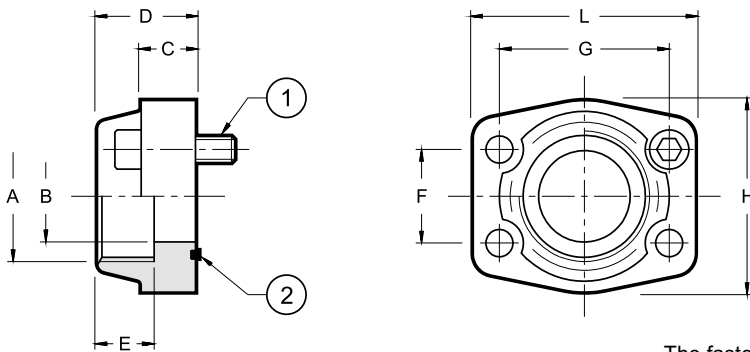

The fastening bolts and the O-Rings must be ordered separately

flange code	flange description	p_{max} [bar]	$\varnothing A$	$\varnothing B$	C	D	E	F	G	H	L	(1) n° 4 bolts	(2)
0610713	SAE - 1"	345	1" BSP	25	18	38	22	26.2	52.4	22	70	SHC M10x35	OR 4131 (32.93x3.53)
0610720	SAE - 1 1/4"	276	1 1/4" BSP	32	21	41	22	30.2	58.7	68	79	SHC M10x35	OR 4150 (37.69x3.53)
0610714	SAE - 1 1/2"	207	1 1/2" BSP	38	25	44	24	35.7	70	78	93	SHC M12x45	OR 4187 (47.22x3.53)
0610721	SAE - 2"	207	2" BSP	51	25	45	30	43	77.8	90	102	SHC M12x40	OR 4225 (56.74x3.53)